

XP S E R I E S

Pneumatici omologati CIK/FIA 2005-2007 di
mescola morbida
Homologation CIK/FIA 2005-2007 tyres of
soft compound



- 1
- 2
- 3
- 4
- 5
- 6
- 7
- 8
- 9



High Technology in Karting Tyres

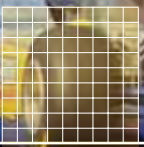

yellow label

XP



VEGA

5"

→ omologazione CIK/FIA 2005-2007 → 2005/2007 CIK/FIA homologation → omologazione CIK/FIA 2005-2007

XP S E R I E S

Pneumatici omologati CIK/FIA 2005-2007 di
mescola morbida
Homologation CIK/FIA 2005-2007 tyres of
soft compound



Pneumatici VEGA di nuova omologazione CIK/FIA per gli anni 2005/2007 di mescola "morbida".

XP è l'ulteriore evoluzione tecnologica della già vincente "gialla" XT, dominatrice della Coppa del Mondo nella categoria Super Ic-C 2004 con l'ottimo Ennio Gandolfi (Birel-TM) e 2003 con Robert Dircks (Birel-TM) .

Costruite con mescole e carcasse di massimo livello tecnologico, le nuove XP assicurano prestazioni uniche in termini di grip, scorrevolezza e facilità di guida.

Quest'ultimo aspetto, in particolare, è sempre stato motivo di esaltazione da parte dei piloti secondo i quali "le gialle sono i pneumatici più facili da guidare".



- [1] **Ennio Gandolfi**
1° World Cup 125 Super ICC - 2004
- [2] **Davide Foré**
1° Italian Open Master Championship 100 FA - 2004
- [3] **Francesco Laudato**
1° European Championship 125 Super ICC - 2004



High Technology in Karting Tyres



rear

front

VEGA

These are the new Vega soft compound tyres for the CIK/FIA homologation period 2005/2007.

The XP tyre is the latest evolution of the already successful "yellow label" XT, which has dominated the 2004 Super Ic-C World Cup thanks to the Italian driver Ennio Gandolfi (Birel-TM) and also the 2003 edition won by Robert Dircks (Birel-TM).

The structure and compound engineering are both at the cutting edge of tyre technology, so that the new XP tyre assures unique performance in the terms of grip, rolling resistance and finally an outstanding distinction, easiness of driving.

All the drivers say that "the yellow tyres are the easiest to drive!"



F. Laudato, E. Gandolfi, R. Toninelli

- 1
- 2
- 3
- 4
- 5
- 6
- 7
- 8
- 9



2.



3.

Dati tecnici

Technical Data

XP

Misura / Size	10x4.60-5	11x7.10-5
L mm ±5	133	208
B mm ±5	105	142
C mm ±3	120	198
d mm +0 -1	126,2	126,2
D mm ±6	259	273
Durezza Superficial thread hardness	IRHD ±3 35	35
Peso ±5% Weight ±5%	Kg. 1,135	1,620
Press. Sug. ±0.2 Sug. Press. ±3	BAR 0,56	PSI 8
Velocità max Max Speed	Km/h 125	Mp/h 125

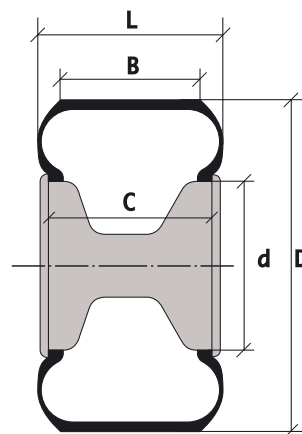

XP



High Technology in Karting Tyres

VEGA

Vega S.p.A.

Via Archimede, 10 · 21047 Saronno (VA) - Italy

Tel. (+39) 02.96451201 · Fax (+39) 02.96451192

vegadeal@vegatyres.com